

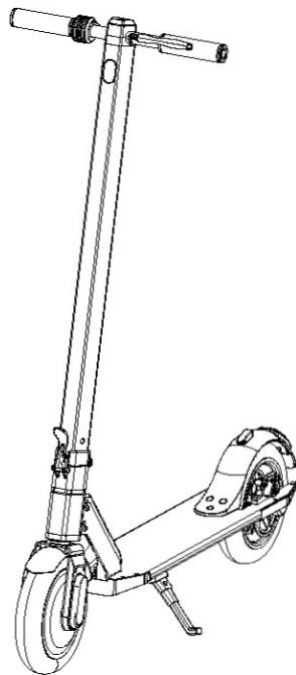

Universal Instruction USER MANUAL

Model: S5

Thank you for purchasing our product. For optimum performance and safety, please read this manual carefully before operating the product. Please keep this manual for future reference.



CATALOG

1. General Information	01
2. Product Overview	02
2.1 General information	02
2.2 What you need to know	02
3. Product Description	03
3.1 Assembly	03
3.2 Folding	03
3.3 Unfolding	03
4. How to ride	04
5. SCOOTER SAFETY PRECAUTIONS	06
6. Weight and Speed Limitations	07
6.1 Weight Restrictions	07
6.2 Speed Limits	07
7. Operating Range	07
8. Battery Information and Specifications	07
9. Charging your scooter	08
10. Inspection, Maintenance, and Storage	09
11. Scooter Specifications	09

1. General Information

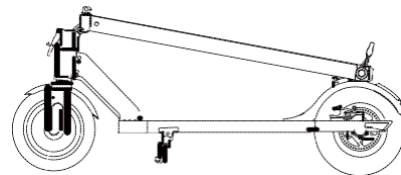
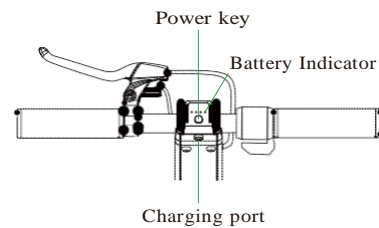
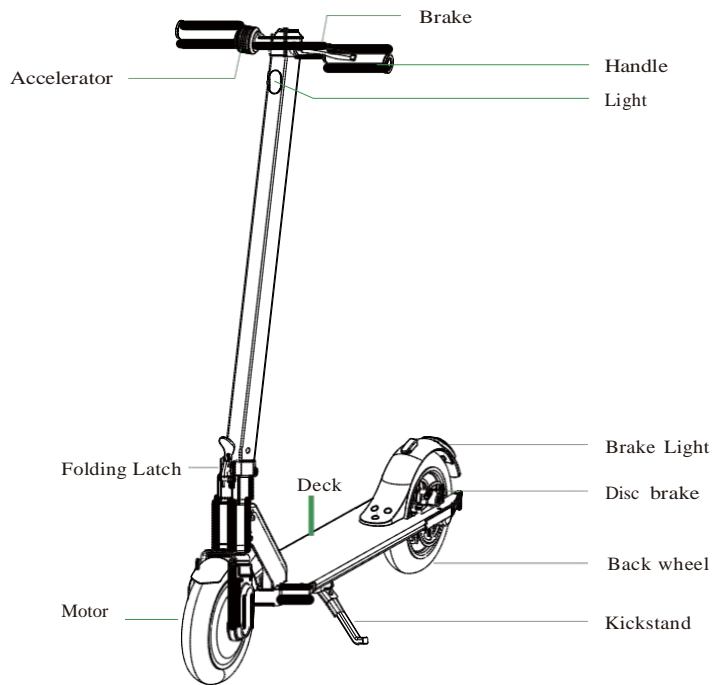

2. Product Overview

2.1 General information

The original scooter is an intuitive, technologically advanced solution. Using the latest technology and production processes, each scooter undergoes strict testing for quality and durability. With its lightweight, portable design, ease of use, range, and low carbon footprint.

2.2 What you need to know

Before you first experience your scooter, please read the **USER MANUAL** thoroughly and learn the basics to ensure your safety and the safety of others.

The power will be shut down if nobody operate in five minutes, you need press power button before you ride.



WARNING Failure to follow the basic instructions and safety precautions listed in the **USER MANUAL**, can lead to damage to your scooter, other property damage, serious bodily injury, and even death.

3. Product Description

3.1 Unfolding

You can unfold the Smart Kick Scooter without any inconvenience in seconds.

When unfold the scooter, press down the hook until it can get way from the buckle of rear fender. Hold the front pole upright, then pull up the folding lever and push back the folding mechanism to fasten the folding construction.

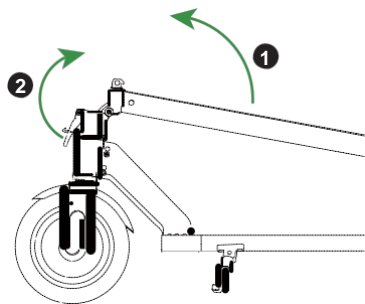

3.2 Assembly

The Smart Kick Scooter can be assembled within 2 minutes:

Install the Handlebars and tighten the handles.

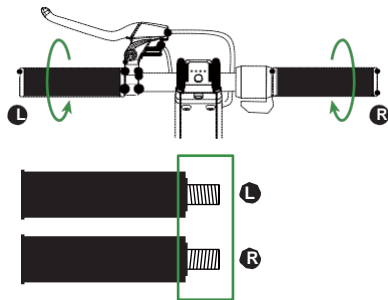

Before installing the handles, please make sure to differentiate the left & right handles carefully. Please see the difference of left & right handles from below images.

3.3 Folding

Make sure the scooter is off. One hand holds the front pole, and presses the lock buckle of folding mechanism while pull up the lever of folding mechanism, and then pushes down the folding lever, matches the hook on top horizontal pole with the buckle of rear fender and push down to make hook and buckle connect together.

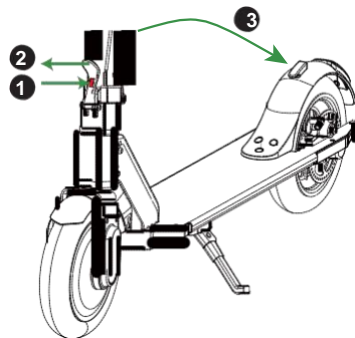

4. How to ride



Warning: There is risk of falling down during learning, so make sure to wear helmet and protection kits all the time.



1. Turn on the scooter by press and check the battery power.

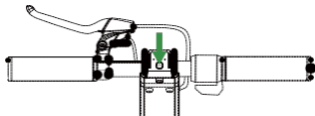

3. Press the power button once to turn on the light;
Press power button twice to switch gears.

First gear (The rightmost LED light flashes blue): MAX speed 18km/h
Second gear (The rightmost LED light flashes red): MAX speed 25km/h

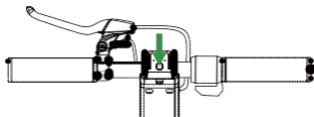

2. Once the power is on it is safer to start riding with one foot on the deck keeping the other foot on the ground for pull off, once the speed up to 6km/h then push accelerator and place the other foot on the deck, this is safer and more controlled than pulling off with two feet on the deck as you will have less control and stability with two feet on the deck.

Skillfully use the accelerate throttle valve to speed up or slow down when riding.

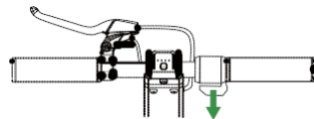

4. Press the brake handle to stop the scooter. Do not stop suddenly!

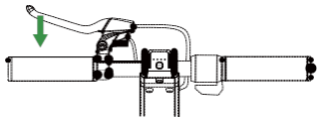

5. Turn off the scooter when finish using the product. .

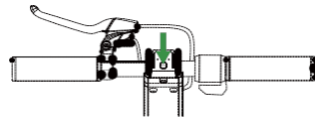

5. SCOOTER SAFETY PRECAUTIONS

Failure to follow any of the following safety precautions can and may lead to damage to your scooter, void your manufacturer warranty, lead to property damage, cause serious bodily injury, and can lead to death.

1. Please wear all appropriate safety and protective gear as previously mentioned in the User Manual before operating the scooter.
2. Make sure to wear comfortable clothes and flat closed toe shoes when operating your scooter.
3. Please carefully read the User Manual, which will assist in explaining the basic working principles and provide tips on how to best enjoy your scooter experience.
4. Do not try to open or modify your scooter, as doing so will void your manufacturer warranty, and may cause failure to your device leading to serious bodily injury or death.
5. Do not use the scooter to place yourself or anyone else and their property in danger.
6. Do not operate the scooter while under the influence of drugs and/or alcohol.
7. Do not operate the scooter when you are restless or sleepy.
8. Use your best judgment to keep yourself out of dangerous situations with your scooter.
9. Do not ride your scooter off of curbs, ramps, or attempt to operate in a skate park, empty pool, or in any ways similar to a skateboard or scooter.

THE SCOOTER IS NOT A SKATEBOARD.

10. Do not turn sharply, especially at high speeds.
11. Do not abuse your scooter, doing so can damage your unit and cause failure to the operating system leading to injury.
12. Do not drive in or near puddles of water, mud, sand, stones, gravel, debris or near rough and rugged terrain.
13. The scooter can be used on paved roads that are flat and even. If you encounter uneven pavement, please lift your scooter over and past the obstruction.
14. Do not ride in inclement weather: snow, rain, hail, sleet, on icy roads or in extreme heat.
15. Do not ride in or near pools or other large bodies of water.
16. For Bumps and Uneven pavement-Bend your knees when riding on bumpy or uneven pavement to absorb the shock and vibration and help you keep your balance. If you are unsure if you can safely ride on a specific terrain, step off and carry your scooter. ALWAYS ERR ON THE SIDE OF CAUTION.
17. Do not attempt to ride over bumps or objects greater than 1.5cm even when prepared and bending your knees.
18. PAY ATTENTION - look at where you are riding and be cognoscente of the road conditions, people, places, property and objects around you.
19. Do not operate the scooter in crowded areas.
20. Operate your scooter with extreme caution when indoors, especially around people, property, and narrow spaces like doorways and other narrow spaces.
21. Operate your scooter with extreme consideration for people and property at all times.

22. Do not operate the scooter while talking, texting, or looking at your phone.
23. Do not ride your scooter where it is not permitted.
24. Do not ride your scooter near motor vehicles or on public roads.
25. Do not climb or travel down steep hills with your scooter.
26. The scooter is intended for use by a single individual, DO NOT attempt to operate the scooter with two or more people.
27. Do not carry anything while riding the scooter.
28. Individuals with lack of balance should not attempt to operate the scooter.
29. Women who are pregnant or who may become pregnant should not operate the scooter.
30. Young children and the elderly should not operate the scooter without proper instruction and supervision from a Certified scooter trainer.
31. At higher speeds, always take into consideration longer stopping distances.
32. Do not step forward off your scooter.
33. Do not attempt to jump on or off your scooter.
34. Do not attempt any stunts or tricks with your scooter.
35. Do not ride the scooter in dark or poorly lit areas.
36. Do not ride the scooter near or over potholes, cracks or uneven pavement.
37. Do not operate your scooter off-road.
38. Do not exceed the maximum or minimum weight limits.
39. Avoid driving the scooter in unsafe places, including near areas with flammable gas, steam, liquid, dust, fiber, which could cause fire and explosion accidents.

6. Weight and Speed Limitations



PLEASE NOTICE

Speed and weight limits are set for your own safety. Please do not exceed the limits listed in the User Manual.

6.1 Weight Restrictions

Maximum Weight: 120 kg.

6.2 Speed Limits

Speed level: 1--Max 15km/h 2--Max 23km/h

7. Operating Range

Please notice the scooter can travel a distance of 12-16km on a fully charged battery in ideal conditions. The following are some of the major factors that will affect the operating range of your scooter.

Terrain: A smooth, flat surface will increase your driving distance, while driving uphill, as well as rough or uneven terrain will reduce your distance significantly.

Weight: The weight of the user can affect driving distance, a lighter user will have further range than a heavier user.

Ambient temperature: Please ride and store the scooter under recommended temperatures, which will increase driving distance; battery life, and overall performance of your scooter.

Maintenance: Reasonable battery charging and maintenance will increase the distance. Overcharging the battery can reduce range.

Speed and Driving Style: Maintaining a moderate speed will increase your distance; while travelling at high speeds for extended periods, frequent starts, stops, idling, along with frequent acceleration and deceleration will reduce your overall distance.

8. Battery Information and Specifications

This section is intended to provide you basic information about your battery and charger. Please read this section carefully to ensure you. For user safety and to prolong the life of your battery, as well as improve battery performance, please follow these instructions.

When the battery indicator shows low battery capacity, please charge your battery 3 hours utilizing the charger that you received in your scooter package. To fully recharge your battery please follow the instructions under charging your scooter.

8.1 Weight Restrictions

Battery Specifications

Battery	Lithium Battery
Charging time	3 hours
Voltage	36 V
Initial Capacity	5200 mAh
Working Temperature	-15° ~ 50°
Charging Temperature	0° ~ 40°
Storage Time	6 months
Storage Temperature	-20° - 25°
Storage Humidity	5%-95%

BATTERY WARNING

Failure to follow the Safety Precautions listed in the Battery Warning could lead to serious bodily injury and death. Seek immediate medical attention if you are exposed to any substance that is emitted from the battery.

- Do not attempt to modify, change, or replace your battery.
- Do not use your scooter if the battery begins to emit odor, overheats, or begins to leak.
- Do not touch any leaking materials, or breathe fumes emitted.
- Do not allow children and animals to touch the battery.
- The battery contains dangerous substances, do not open the battery, or insert anything into the battery.
- Please only use the charger provided by scooter.
- Do not attempt to charge the scooter if the battery has discharged or emitted any substances. In that case, the battery should be abandoned for safety.
- Please follow all local, state and federal laws in regards to recycling, handling and disposing of Lithium Ion batteries.

- The scooter should only be shipped in its original packaging.
- Do not throw away your box as you need your scooter packaging for future use.

Capacity Indicator Instruction

Total 4 LED lights, full capacity with all lights on, the capacity will drop 25% when one LED light is off until the last light turns to red.

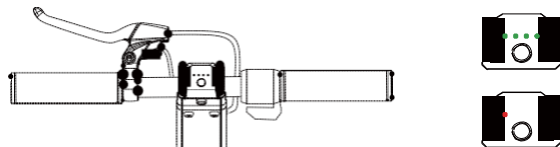

9. Charging your scooter

- Step 1: Ensure that the charging port is clean and dry.
- Step 2: Plug the charger into the power socket, then connect the cable with the power supply (100V~240V; 50,60Hz), make sure the light on the charger is lit GREEN.
- Step 3: Male DC connector plug into the charging port of the scooter. The indicator light on the charger should change to RED, indicating that your scooter is now being charged. When the RED indicator light on your charger turns to GREEN then your scooter is fully charged. A full charge typically occurs within 3 hours.
- Step 4: Please unplug the charger from your scooter and from the power outlet.



IMPORTANT NOTES ABOUT CHARGING

If the green light on your charger does not turn RED when you plug it into your scooter, it could mean you have to check the cables to ensure you have a proper connection; or that your scooter is already fully charged. Push and hold your power button next to the charging port to check the status of your battery in the display.

- Do not overcharge, as this will affect the life of the battery.
- The best charging temperatures are between 0°~40°. Extreme cold and extreme heat will prevent your battery from charging fully.
- Make sure to unplug your charger before standing on or operating your scooter, as this can be very dangerous.



- Use only the scooter charger that you received in your box.
- If the scooter is powered on when you enter the plug, the Battery Indicator will begin blinking, if the scooter is powered off when you enter the plug, the Battery Indicator will not blink.



NOTE

Only the indicator light on the charger will tell you the status of the battery during charging.

10. Inspection, Maintenance, and Storage

Your scooter requires routine inspection and maintenance. This chapter describes maintenance steps and important operating tips. Before you perform the following operations, ensure the power and charging cable is disconnected.

Inspecting and Cleaning your scooter

Disconnect the charger and turn off your scooter.

Routinely check the body of the scooter and tires for damage or excessive wear. Avoid using water or other liquids and cleaners on the scooter for cleaning. Wet a clean cloth with clean soapy water, rinse the cloth thoroughly, and wipe the

body of the scooter making sure that water does not get into the power button, charging port, the foot mats, or tires.

Storing your scooter

Fully charge your battery before storing.

If you are storing your scooter for an extended period of time, please fully charge your scooter at least once every three months.

If the ambient temperature of the storage location is below 0°, please do not charge. You must bring the scooter into a warmer environment before charging. Check under Battery Information and Specifications for more details.

To prevent dust from getting into your scooter, try wrapping it or sealing it with its original packaging.

Store your scooter indoors, in a dry and suitable temperature.



NOTE

Users who disassemble the scooter will forfeit their right of warranty.

11. Scooter Specifications

- Net Weight: 11.9 kg
- Load: 120 kg
- Speed level: 1--Max 15km/h 2--Max 23km/h
- Range: 12-16 km
- Max. Climbing Limit: 20 degree
- Battery: Lithium-ion, 5.2 Ah, 36 V
- Power Requirement: AC 100-240V / 50-60Hz
- Size (fold): 110 x 42 x 43 cm
- Size (unfold): 111 x 42 x 120 cm
- Platform Height: 15 cm
- Tire: Pneumatic tire

Thank you

Thank you for the purchase of your new scooter, and thank for taking the time to read the User Manual. We hope that the information that you obtained from this manual will help you safely operate, maintain and enjoy your scooter for years to come. We appreciate your consideration and sincerely hope you enjoy and share your scooter experience with all of your friends, family members, and loved ones. Thank you and welcome to the scooter movement!
Enjoy your scooter!